

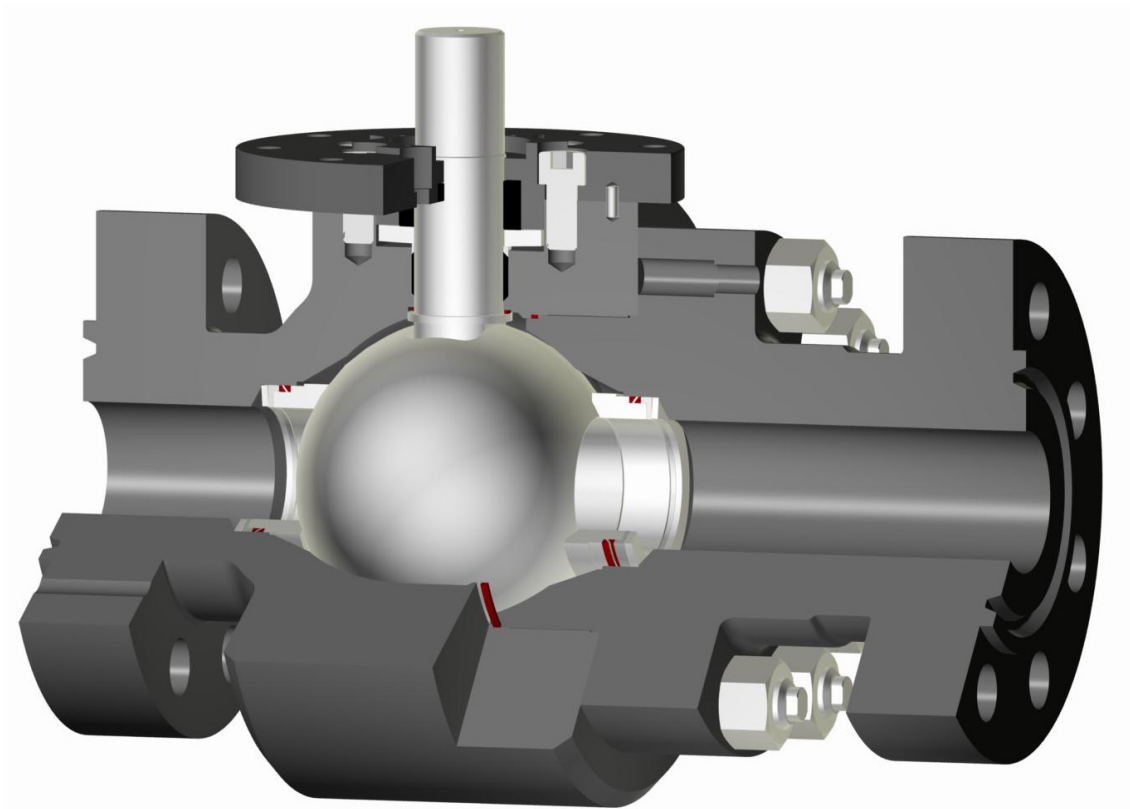

Two-Way Metal Seated Ball Valve Type 88-M



Design Characteristics

- ✓ Two piece body
- ✓ Floating ball
- ✓ Blow out proof stem
- ✓ Live loaded stem packing
- ✓ Spring loaded seat system
- ✓ Fire Safe design optional

Design Standards

- ✓ EN 12516, EN 1983, ISO 5211, AD-2000
- ✓ ASME B 16.34, API 608

Range of Application

- ✓ Diameter 2" to 24" / DN 50 to 600
- ✓ Class 150 to 2500 / PN 16 to 420
- ✓ -20°F to +850°F / -60°C to +450°C

Approvals

- ✓ "TA-Luft" certified for low fugitive emissions

Testing Standards

- ✓ EN 12266-1/2
- ✓ API 598



Main Parts

- 1 Body
- 2 Body End Connection
- 4 Retainer Ring
- 5 Ball
- 6 Stem
- 8 Gland Washer
- 10 Bearing Cover
- 16 Plate Spring
- 17 Plate Spring
- 20.1 Body Gasket
- 20.2 Ring
- 20.3 Body Gasket
- 21 Seat Ring
- 23 Body Gasket
- 24 Stem Packing
- 25 Bearing Ring
- 26 Bearing Ring
- 28.1 Set Screw
- 28.2 Nut
- 29 Screw
- 53 Pin

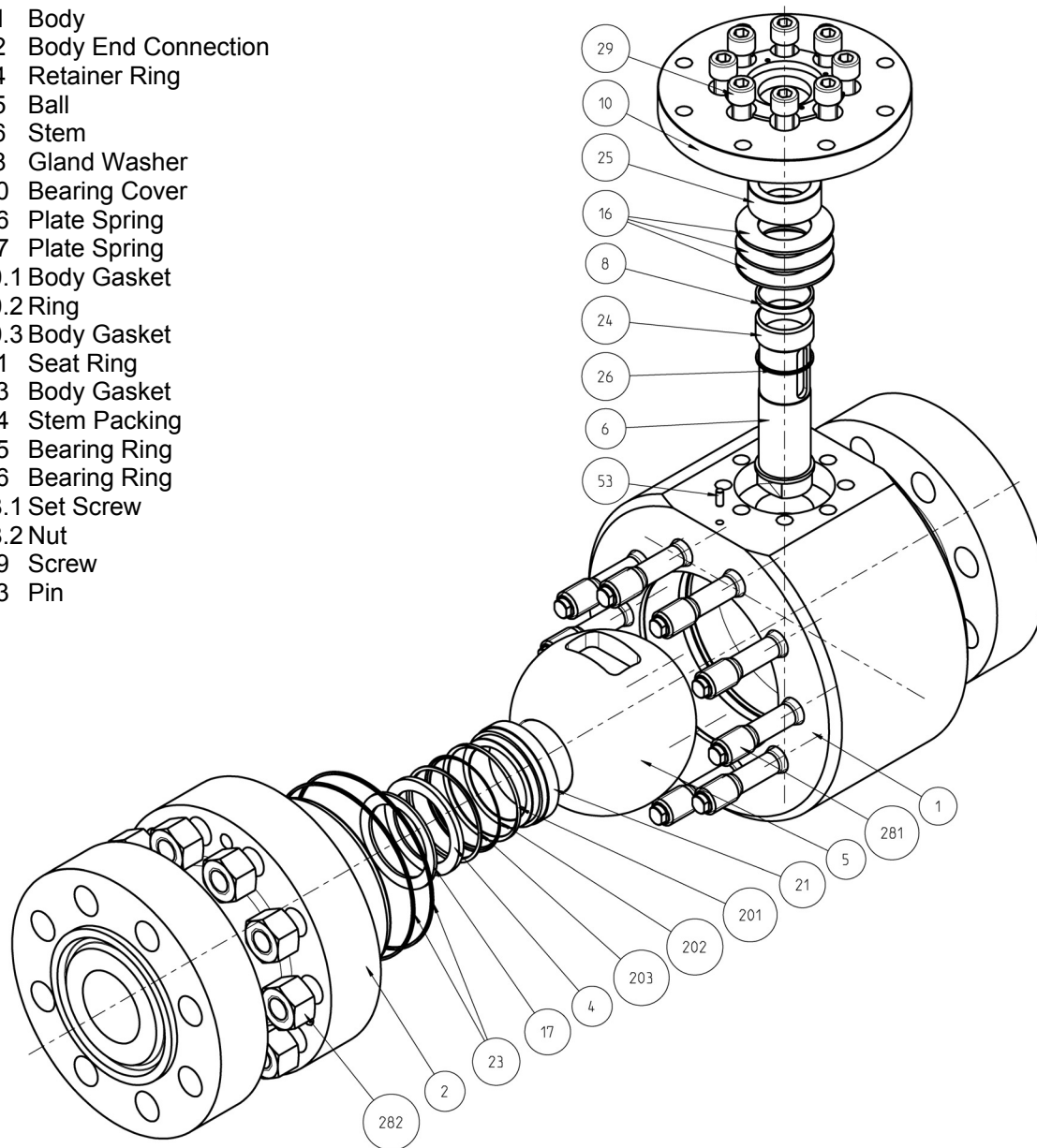

Fig. 1

Description

This PERRIN ball valve is a floating ball design with a two piece split body housing. The spring loaded metallic seat system and live loaded stem packing also provide continuous tightness during short-term temperature and pressure changes. The ball valve is specially designed for transportation of severe solids and high-viscosity fluids such as slurry.

The maximum differential pressure for operating depends on the chosen nominal size and pressure rating and will be decided within the order.

The valve is equipped with an integral actuator mounting flange for actuator connection according to ISO 5211. Stem extensions, locking devices and actuators with accessories, can be attached without operating interruptions.

The ball valve has an antistatic design with blow out proof stem. The stem packing and sealings are "TA-Luft" certified for low fugitive emissions.



Parts List / Materials

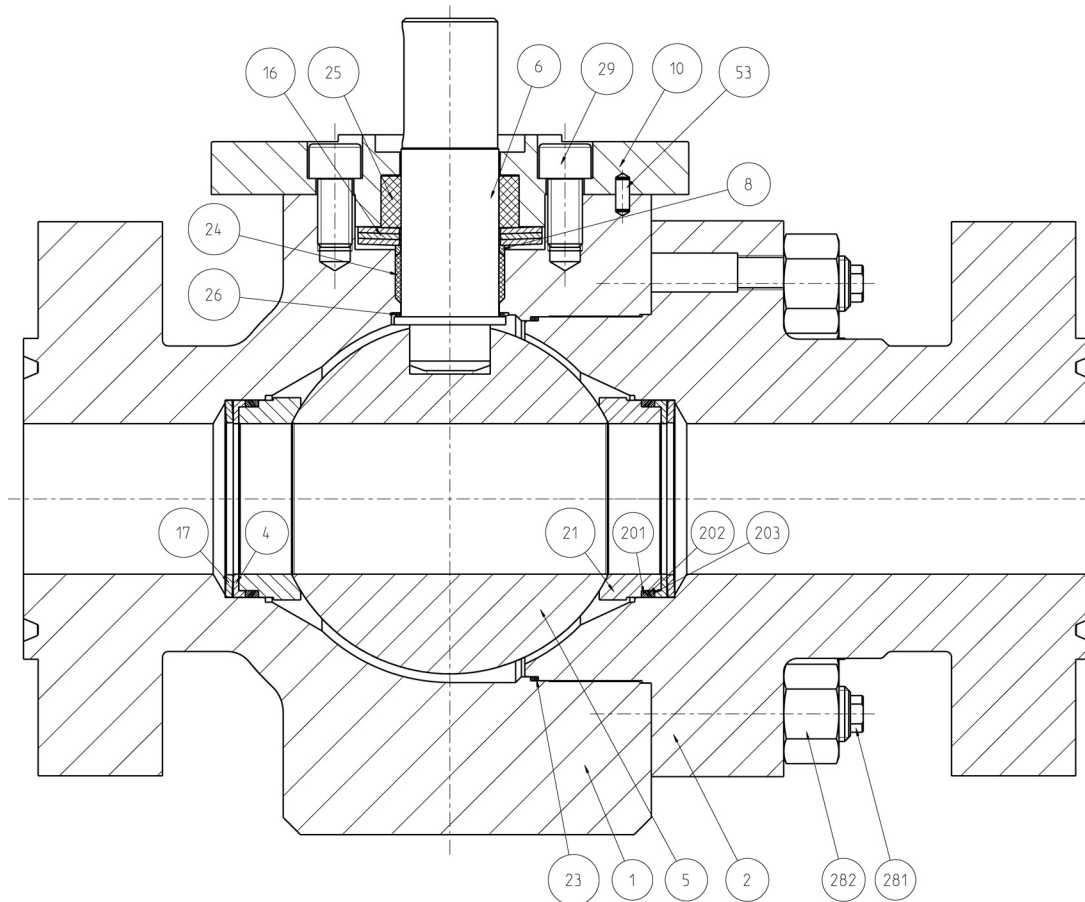

Fig. 2

Item	Designation	ASME	
		-20°F up to +850°F	-20°F up to +850°F
1	Body	A105	A216 WCB
2	Body End Connection		
4	Retainer Ring	Type 316	Type 316
5	Ball	17-4PH coated with Chromium Carbide	17-4PH coated with Chromium Carbide
6	Stem	17-4PH	17-4PH
8	Gland Washer	Type 316	Type 316
10	Bearing Cover	A105	A105
16	Plate Spring ³⁾	AISI 6150	AISI 6150
17	Plate Spring ³⁾	AISI 6150	AISI 6150
20.1	Body Gasket	Graphite	Graphite
20.2	Ring	A105	A105
20.3	Body Gasket	Graphite	Graphite
21	Seat Ring	17-4PH coated with Chromium Carbide	17-4PH coated with Chromium Carbide
23	Body Gasket	Graphite	Graphite
24	Stem Packing		
25	Bearing Ring		
26	Bearing Ring	Graphite with SS	Graphite with SS
28.1	Set Screw	A 193 Gr.B7	A 193 Gr.B7
28.2	Nut	A 194 Gr.2H	A 194 Gr.2H
29	Screw	A 193 Gr.B7	A 193 Gr.B7
53	Pin	A 519	A 519

Tab.1

1) Temperature limitation 300°C [576°F] acc. to German technical rule AD-2000 W5 if intercrystalline corrosion resistant is required
 2) Temperature limitation 280°C [536°F]
 3) Material 2.4668 (Inconel 718) is generally required for operating temperature over 200°C [392°F]
 4) Other materials on request



Technical Data

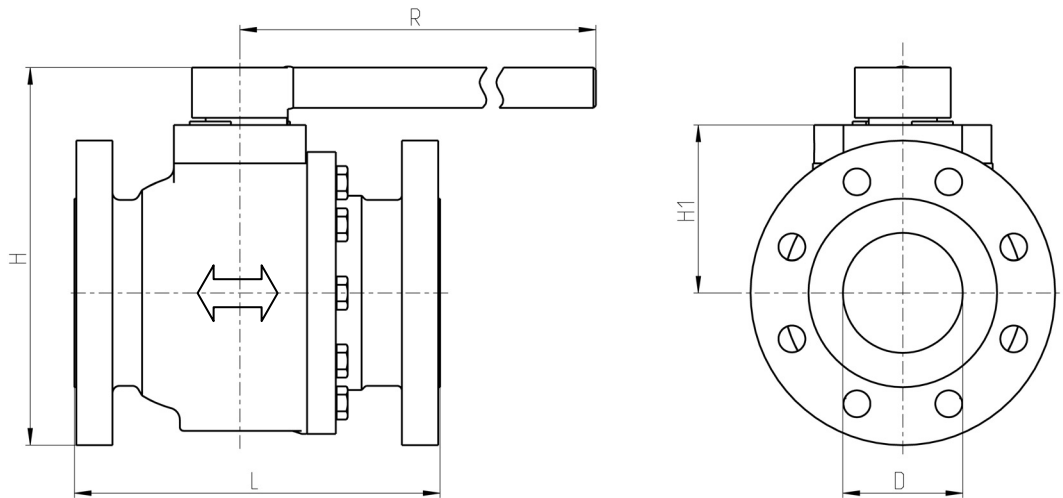

Fig.3

D = NPS = DN = Nominal Size
m = Weight

CLASS 150 - Full Bore

NPS [inch]	DN [mm]	H		H1		R		L ASME B16.10		Cv [gal/min]	m	
		[inch]	[mm]	[inch]	[mm]	[inch]	[mm]	[inch]	[mm]		[lbs]	[kg]
½	15	5,9	150	2,0	51	7	180	4,25	108	27	9	4
¾	20	5,9	150	2,0	51	7	180	4,62	117	47	12	5,5
1	25	6,8	172	2	62	7	180	5	127	74	13	6
1¼	32	7	190	2,7	68	7	180	5,5	140	123	22	10
1½	40	8,1	206	3	81	12	300	6,5	165	191	31	14
2	50	8,9	226	4,0	101	12	300	7	178	298	37	17
2½	65	9,7	247	4,2	106	12	300	7,5	190	504	55	25
3	80	12,2	309	5	125	18	450	8	203	763	77	35
4	100	13	342	6	140	18	450	9	229	1192	97	44

Tab.2

CLASS 150 - Reduced Bore

NPS [inch]	NPS-R [inch]	H		H1		R		L ASME B16.10		Cv [gal/min]	m	
		[inch]	[mm]	[inch]	[mm]	[inch]	[mm]	[inch]	[mm]		[lbs]	[kg]
¾	½	6,3	161	2	51	7	180	4,62	117	24	10	4,5
1	¾	6,3	161	2	51	7	180	5	127	43	13	6
1¼	1	7	177	2,4	62	7	180	5,5	140	67	17	7,5
1½	1¼	7,9	201	2,7	68	7	180	6,5	165	110	25	11,5
2	1½	8,3	211	3,2	81	12	300	7	178	172	33	15
2½	2	9,4	239	4	101	12	300	7,5	190	268	44	20
3	2½	10,1	257	4,2	106	12	300	8	203	454	64	29
4	3	12,7	322	4,9	125	18	450	9	229	687	79	36

Tab.3



CLASS 300 - Full Bore

NPS [inch]	DN [mm]	H		H1		R		L ASME B16.10		Cv [gal/min]	m	
		[inch]	[mm]	[inch]	[mm]	[inch]	[mm]	[inch]	[mm]		[lbs]	[kg]
½	15	5,9	151	2,0	51	7	180	5,5	140	27	11	5
¾	20	6,2	157	2,0	51	7	180	6	152	47	14	7
1	25	6,6	168	2	62	7	180	6,5	165	74	18	8
1¼	32	7,3	186	2,7	68	12	300	7	178	123	29	13
1½	40	8,5	217	3	81	12	300	7,5	190	191	37	17
2	50	9	228	4,0	101	12	300	8,5	216	298	48	22
2½	65	9,7	247	4,2	106	12	300	9,5	241	504	73	33
3	80	12	305	4,9	125	18	450	11,12	282	763	92	42
4	100	13,5	343	6	140	28	700	12	305	1192	123	56

Tab.4

CLASS 300 - Reduced Bore

NPS [inch]	NPS-R [inch]	H		H1		R		L ASME B16.10		Cv [gal/min]	m	
		[inch]	[mm]	[inch]	[mm]	[inch]	[mm]	[inch]	[mm]		[lbs]	[kg]
¾	½	6,4	162	2	51	7	180	6	152	24	13	6
1	¾	6,4	162	2	51	7	180	6,5	165	43	16	7
1¼	1	6,8	173	2,4	62	7	180	7	178	67	20	9
1½	1¼	7,8	197	2,7	68	7	180	7,5	190	110	33	15
2	1½	8,7	222	3,2	81	12	300	8,5	216	172	43	20
2½	2	9,5	241	4	101	12	300	9,5	241	268	56	25
3	2½	10,1	257	4,2	106	12	300	11,12	282	454	83	38
4	3	12,4	315	4,9	125	18	450	12	305	687	106	48

Tab.5



CLASS 600 - Full Bore

NPS [inch]	DN [mm]	H		H1		R		L ASME B16.10		Cv [gal/min]	m	
		[inch]	[mm]	[inch]	[mm]	[inch]	[mm]	[inch]	[mm]		[lbs]	[kg]
½	15	6,4	163	2,2	55	12	300	6,5	165	27	15	7
¾	20	6,8	173	2,3	59,5	12	300	7	190	47	22	10
1	25	6,8	173	2,3	58	12	300	8,5	216	74	29	13

Tab.6

CLASS 900 - Full Bore

NPS [inch]	DN [mm]	H		H1		R		L ASME B16.10		Cv [gal/min]	m	
		[inch]	[mm]	[inch]	[mm]	[inch]	[mm]	[inch]	[mm]		[lbs]	[kg]
½	15	6,7	171	2,3	58	12	300	8,5	216	27	26	12
¾	20	6,9	176	2,3	58	12	300	9	229	47	29	13
1	25	7,4	187	2,3	59	12	300	10	254	74	37	17

Tab.7

CLASS 1500 - Full Bore

NPS [inch]	DN [mm]	H		H1		R		L ASME B16.10		Cv [gal/min]	m	
		[inch]	[mm]	[inch]	[mm]	[inch]	[mm]	[inch]	[mm]		[lbs]	[kg]
½	15	6,7	171	2,3	58	12	300	8,5	216	27	26	12
¾	20	6,9	176	2,3	58	12	300	9	229	47	29	13
1	25	7,4	187	2,3	59	12	300	10	254	74	37	17

Tab.8

PN 16 – PN 40

DN [mm]	H [mm]	H1 [mm]	R [mm]	L [mm] DIN EN 558		Kv [m³/h]	m [kg]	
				GR1	GR27		GR1	GR27
15	150	51	180	130	115	23	4	3
20	150	51	180	150	120	41	5	4
25	172	62	180	160	125	64	6	5
32	190	68	300	180	130	106	8	7
40	206	81	300	200	140	165	10	9
50	226	101	300	230	150	258	12	11
65	247	106	300	290	170	436	19	17
80	309	125	450	310	180	660	25	21
100	342	140	700	350	190	1031	35	29

Tab.9

Other dimensions and pressure classes on request.

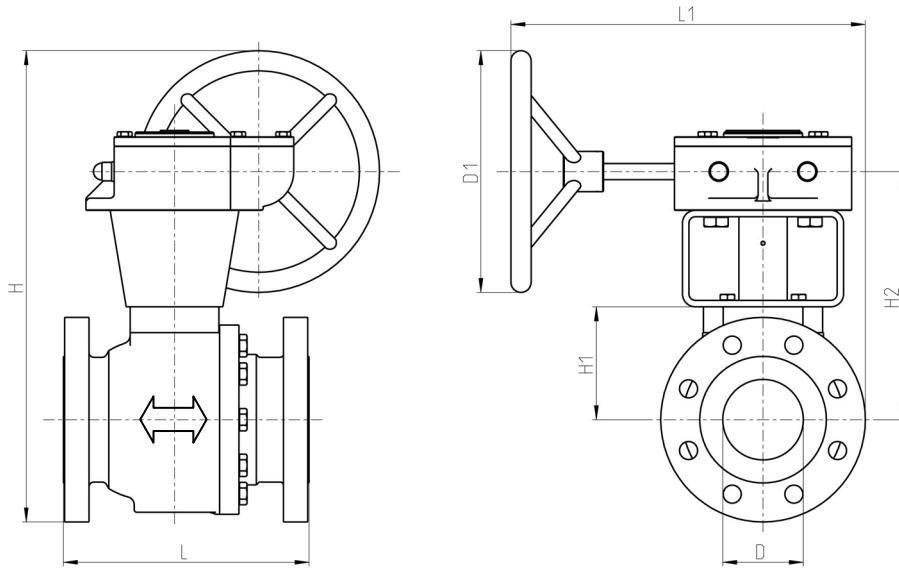

Fig.4

D = NPS = DN = Nominal Size
m = Weight

CLASS 150 - Full Bore

NPS [inch]	DN [mm]	H		H1		H2		L1		D1		L ASME B16.10		Cv [gal/min]	m	
		[inch]	[mm]	[inch]	[mm]	[inch]	[mm]	[inch]	[mm]	[inch]	[mm]	[inch]	[mm]		[lbs]	[kg]
6	150	31,9	811	7,8	197	13	321	14,7	373	28	700	15,5	394	2548	295	134
8	200	35,6	903	9,5	241	15	382	18	467	28	700	18	457	4528	486	221
10	250	38	966	11,1	282	18,2	463	21	528	24	600	21	533	7358	779	354
12	300	43	1097	13	338	21,9	556	24	600	24	600	24	610	10190	1118	508

Tab.10

CLASS 150 - Reduced Bore

NPS [inch]	NPS-R [inch]	H		H1		H2		L1		D1		L ASME B16.10		Cv [gal/min]	m	
		[inch]	[mm]	[inch]	[mm]	[inch]	[mm]	[inch]	[mm]	[inch]	[mm]	[inch]	[mm]		[lbs]	[kg]
6	4	19,3	489	5,5	140	10,4	264	12,3	312	18	450	15,5	394	1676	223	101
8	6	32,6	828	7,8	197	13,3	338	14,7	373	28	700	18	457	2414	339	154
10	8	37,1	943	9,5	241	16,6	422	18,4	467	28	700	21	533	4291	559	254
12	10	39,5	1003	11,1	282	19,7	500	20,8	528	24	600	24	610	6972	894	407

Tab.11

CLASS 300 - Full Bore

NPS [inch]	DN [mm]	H		H1		H2		L1		D1		L ASME B16.10		Cv [gal/min]	m	
		[inch]	[mm]	[inch]	[mm]	[inch]	[mm]	[inch]	[mm]	[inch]	[mm]	[inch]	[mm]		[lbs]	[kg]
6	150	33	841	9	241	15	382	20	515	24	600	15,9	403	2548	383	174
8	200	35	880	11	282	18	464	23	588	18	450	20	502	4528	608	277
10	250	42	1058	13	338	25	636	27	679	16	400	22	568	7358	938	427
12	300	52	1310	18	452	30	750	30	770	24	600	26	648	10190	1469	668

Tab.12

CLASS 300 - Reduced Bore

NPS [inch]	NPS-R [inch]	H		H1		H2		L1		D1		L ASME B16.10		Cv [gal/min]	m	
		[inch]	[mm]	[inch]	[mm]	[inch]	[mm]	[inch]	[mm]	[inch]	[mm]	[inch]	[mm]		[lbs]	[kg]
6	5	28	701	7,8	197	13	338	12	315	28	700	15,9	403	1676	319	145
8	6	34	865	9	241	15	382	20	515	24	600	20	502	2414	507	230
10	8	40	1006	11	282	18	464	23	588	18	450	22	568	4291	782	355
12	10	43	1083	13	338	25	636	27	679	16	400	26	648	6972	1224	556

Tab.13



CLASS 600 - Full Bore

NPS [inch]	DN [mm]	H		H1		H2		L1		D1		L ASME B16.10		Cv [gal/min]	m	
		[inch]	[mm]	[inch]	[mm]	[inch]	[mm]	[inch]	[mm]	[inch]	[mm]	[inch]	[mm]		[lbs]	[kg]
1½	40	19	478	4	89	8	201	10	247	8	200	9,5	241	191	73	33
2	50	22	553	4	89	8	213	11	285	12	300	11	292	298	108	49
3	80	35	877	5	125	11	292	12	294	28	700	14	356	763	191	87
4	100	41	1038	6	140	12	311	12	299	35	900	17	432	1192	317	144

Tab.14

CLASS 900 - Full Bore

NPS [inch]	DN [mm]	H		H1		H2		L1		D1		L ASME B16.10		Cv [gal/min]	m	
		[inch]	[mm]	[inch]	[mm]	[inch]	[mm]	[inch]	[mm]	[inch]	[mm]	[inch]	[mm]		[lbs]	[kg]
1½	40	21	540	4	101	9	225	11	290	10	250	12	305	191	97	44
2	50	26	659	4	101	9	225	12	309	18	450	14	368	298	134	61
3	80	35	892	5	125	12	296	14	351	28	700	15	381	763	264	120
4	100	36	918	7	171	14	354	20	503	18	450	18	457	1192	433	197

Tab.15

CLASS 1500 - Full Bore

NPS [inch]	DN [mm]	H		H1		H2		L1		D1		L ASME B16.10		Cv [gal/min]	m	
		[inch]	[mm]	[inch]	[mm]	[inch]	[mm]	[inch]	[mm]	[inch]	[mm]	[inch]	[mm]		[lbs]	[kg]
1½	40	22	566	4	89	8	213	11	290	14	350	12	305	191	114	52
2	50	34	862	4	114	9	240	12	297	31	800	14	368	298	205	93

Tab.16

PN 16

DN [mm]	H [mm]	H1 [mm]	H2 [mm]	L1 [mm]	D1 [mm]	L [mm] DIN EN 558		Kv [m³/h]	m [kg]	
						GR1	GR27		GR1	GR27
150	814	197	321	435	700	480	350	2320	117	101
200	902	241	382	526	700	600	400	4124	192	167
250	966	282	463	600	600	730	450	6701	307	267
300	1086	338	556	687	600	850	500	9279	441	384

Tab.17

PN 40

DN [mm]	H [mm]	H1 [mm]	H2 [mm]	L1 [mm]	D1 [mm]	L [mm] DIN EN 558		Kv [m³/h]	m [kg]	
						GR1	GR27		GR1	GR27
150	965	241	365	506	900	480	350	2320	151	132
200	836	282	423	585	450	600	400	4124	240	209
250	944	338	519	682	400	730	450	6701	371	322
300	1228	452	670	768	600	850	500	9279	580	505

Tab.18

Other dimensions and pressure classes on request.



Features

Ball - **Material for manufacture**

- High strength steels and alloys with tungsten carbide or chromium carbide coating (depending on the process), providing high corrosion resistance (interior and or exterior).
- The application of coating by the process of thermo fusion, called "High Velocity Oxygen Flame Spraying HVOF", is used to minimize wear and erosion of heavy service components.
- The oversized PERRIN ball enables up to 12% more travel (depending on valve nominal size), which reduces problems caused by misalignment. The ball can be recovered when a repair is needed.

Spring system - **Bi-directional tracking seat design**

- The installed plate springs allow the ball and seats to maintain a constant sealing contact, preventing media contamination during pressure shifts.
- Seating surfaces are protected from erosion in the fully opened or closed position.
- Field replaceable seats minimize repair time.

Seat system - **Wide seat sealing surface**

- Wide sealing area creates low stress seal, which is the key in high circuit application.
- Scraper design of seat ring cleans the sealing surface from deposit each time the valve is operated.

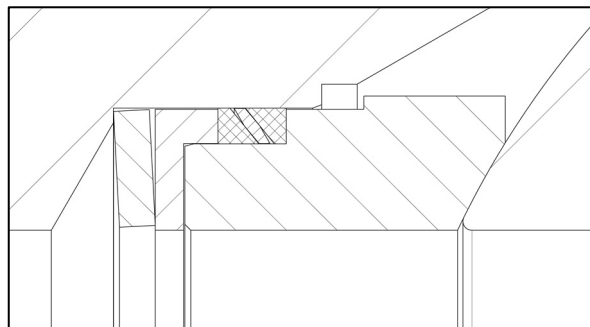

Fig. 5

Locking pins

- The valve can be equipped with additional locking pins to transmit high actuator torques.

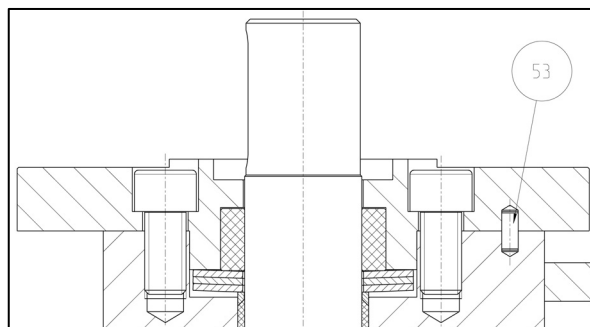

Fig. 6



Options

1. Adjustable stem packing

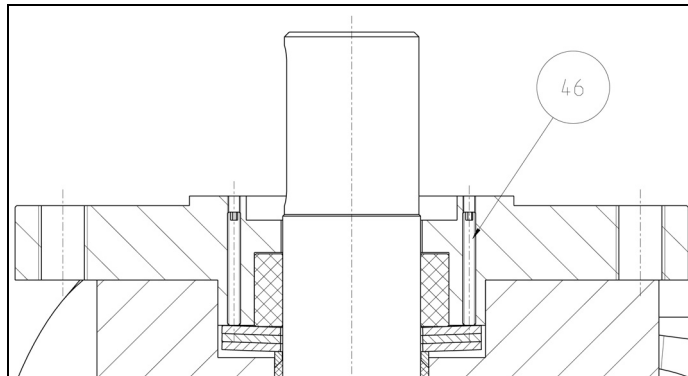

Fig. 7

Additionally the live loaded stem packing may be equipped with hexagon socket screws (46). When tighten these screws it is possible to increase the spring force on the packing in the event of leakage.

2. Body housing - Steel Deposit & HVOF coating

- Steel Deposit in seal housing, along the internal diameter, in packing zone and in internal wetted parts can be applied on request.
- HVOF coating can be applied through the internal diameter and contact surfaces of the ball and seats if required.

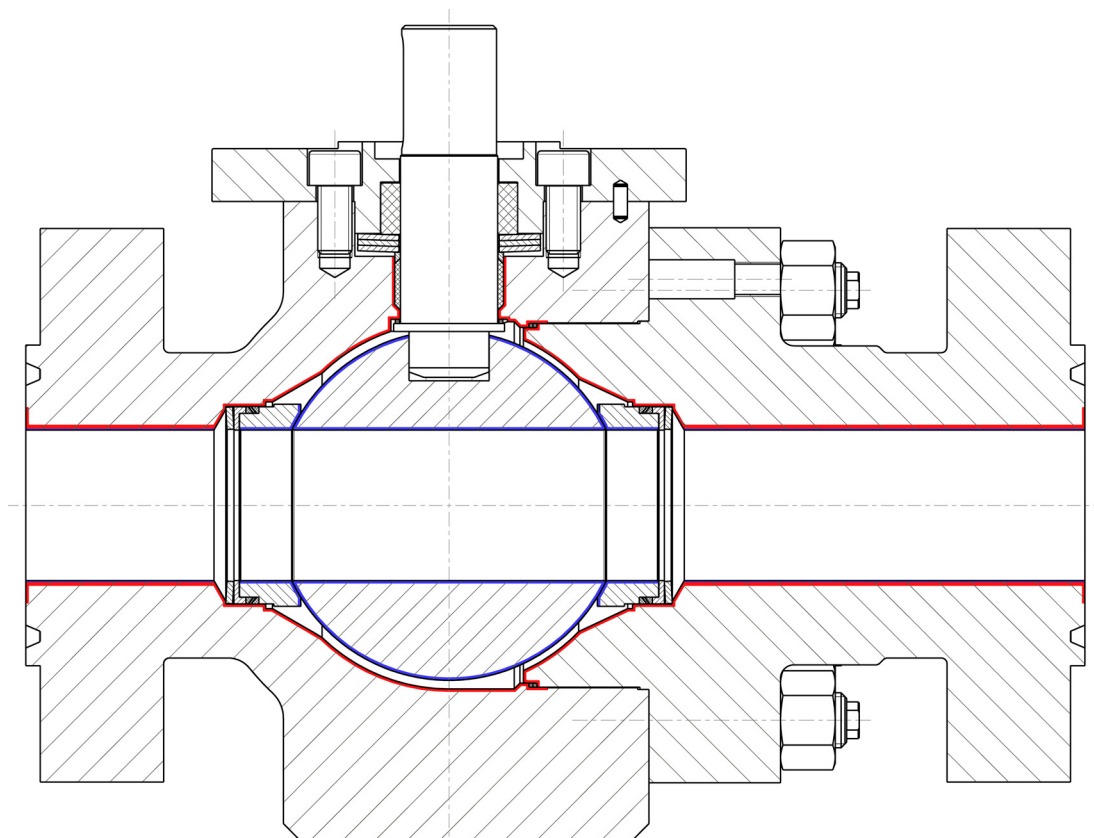
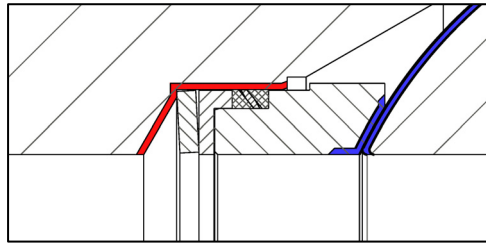

Fig. 8



Coating combinations:

Type 1:



(Red) Stainless steel deposit in seat pocket.

(Blue) HVOF coated on the contact surfaces of the ball and seat rings.

Type 2:

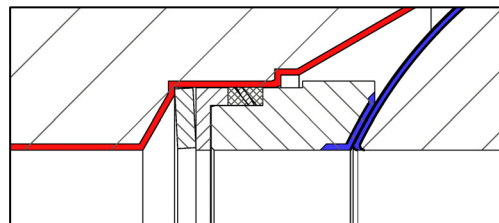

(Red) Stainless steel deposit inside the complete body along all wetted areas.

(Blue) HVOF coated on the contact surfaces of the ball and seat rings.

Type 3:

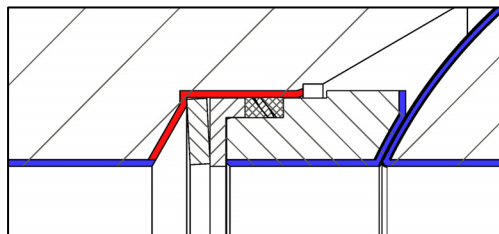

(Red) Stainless steel deposit in seat pocket.

(Blue) HVOF coated on the contact surfaces of the ball, seat rings and along the complete flow path.

Type 4:

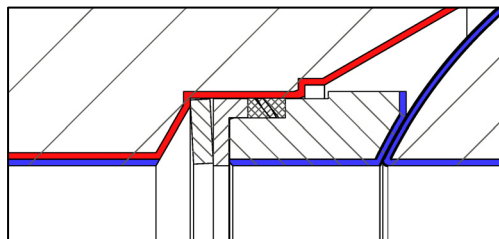

(Red) Stainless steel deposit inside the complete body along all wetted areas.

(Blue) HVOF coated on the contact surfaces of the ball, seat rings and along the complete flow path.

Technical modifications are reserved.

